



KONICA MINOLTA

NEW

Spectrophotometer CM-25cG

1

New standard model for color and gloss measurement!

The two-in-one model that can simultaneously measure both color and gloss!

High inter-instrument-agreement!

Form and functions suitable for measurement of automotive interior trim and materials!



The Standard in Measuring Color & Light

Giving Shape to Ideas

The spectrophotometer CM-25cG is a two-in-one model for simultaneous color and gloss measurement.

Display examples

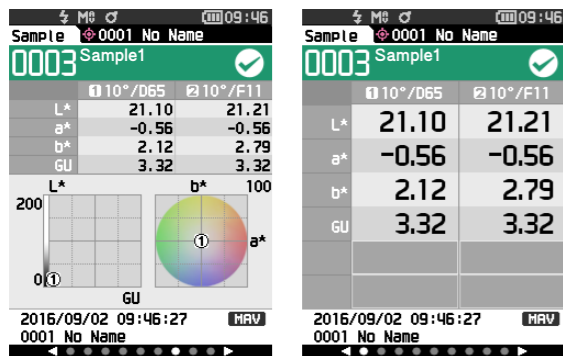

The 2.7-inch TFT color LCD makes measurements easy to read, and the easy-to-understand GUI provides high usability.



Form and functions designed specifically for quality control of color and gloss of automotive interior trim. The industry's next standard model.

Ideal form and functions for measuring automotive interiors



The CM-25cG's sleek, compact, lightweight body is easy to hold, and can measure even in narrow, deep-set spaces. Additionally, changeable apertures allow measurements of subjects which are small or curved.

Color : $\varnothing 8$ mm/ $\varnothing 3$ mm
Gloss : $\varnothing 10$ mm/ $\varnothing 3$ mm

A two-in-one model for color and gloss



The CM-25cG greatly improves work efficiency by eliminating the need to switch between two instruments — one for color, one for gloss — for each measurement, thus reducing takt time, and providing color and gloss data from exactly the same measurement point for more accurate quality control.

High inter-instrument agreement



The CM-25cG offers high inter-instrument agreement of within $\Delta E^* 0.15$ (typical) (MAV) for color and ± 0.2 GU for gloss measurements of 1 to 10 GU. This high inter-instrument agreement enables digital data management for more efficient quality control among your factories or between your company and your partners.

High repeatability and user friendliness

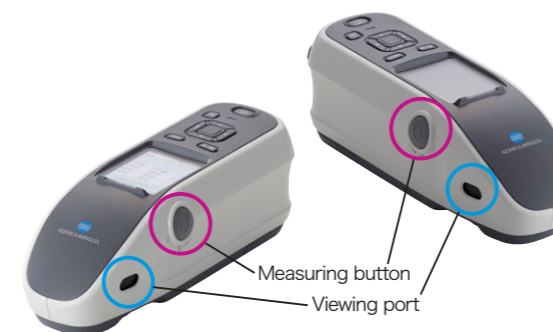

By using a $45^\circ c:0^\circ$ illumination/viewing system with ring-shaped illumination having light sources radially located at certain intervals, the CM-25cG provides stable data while minimizing instrument rotational effects. The system also provides data with high accuracy and repeatability even if there is a small gap between the measurement aperture and the subject.

Other features include high-speed measurement, cable-free operation, and viewing ports and measuring buttons on both the right and left sides of the instrument body for easy operation and high measurement stability in any situation.

* Level of subject visibility through viewing port depends on measurement subject.

Color Data Software SpectraMagic DX (Option) Professional Edition (Version. 1.0) Lite Edition

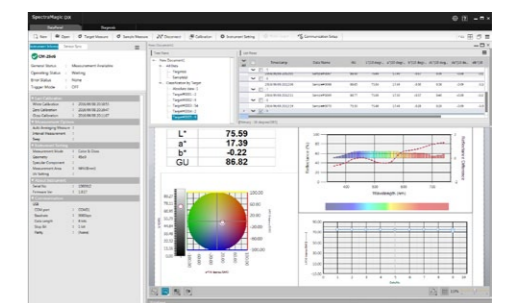

The new Color Data Software SpectraMagic DX enables easy management of data measured with the CM-25cG, and offers a new Instrument Diagnosis function to help ensure continued high instrument performance.

OS : Windows® 7 Pro 32-bit / 64-bit, Windows® 8.1 Pro 32-bit / 64-bit, Windows® 10 Pro 32-bit / 64-bit
CPU : Intel® Core i5 2.7GHz or higher (recommended)
Memory : At least 2 GB (4 GB or more recommended)
Hard disk : 20 GB of available hard disk space
At least 10 GB of available disk space is required on the system drive (drive where the OS is installed) for database.
Display : Display hardware capable of displaying 1,280 x 768 pixels/16-bit color or better
Other : USB port required for protection key if used. Not necessary for electronic license.
USB or serial port required for connection to instrument.
Compatible Instruments : CM-25cG, CM-M6, CM-2500c

• Windows® is a trademark or registered trademark of Microsoft Corporation in the USA and other countries.
• Intel® Core is a trademark or registered trademark of Intel Corporation in the USA and other countries.

Main Specifications

Model	Spectrophotometer CM-25cG
Illumination/viewing system	45°c:0°
Detector	Dual 40-element silicon photodiode arrays
Spectral separation device	Planar diffraction grating
Wavelength range	360-740 nm
Wavelength pitch	10 nm
Half bandwidth	Approx. 10 nm
Measurement range	0-175 %; Output/display resolution : 0.01 %
Light source	Pulsed xenon lamp
Measurement/illumination area	MAV: Ø8 mm / 12×16 mm, SAV: Ø3 mm / 12×16 mm
Repeatability	Chromaticity value: Standard deviation within ΔE^*ab 0.04 (When a white calibration plate is measured 30 times at 10-second intervals after white calibration)
Inter-instrument agreement	Within ΔE^*ab 0.15 (Typical)(MAV) (Based on 12 BCRA Series II color tiles compared to values measured with a master body under Konica Minolta standard measurement conditions)
Observer	2° or 10° Standard Observer
Illuminant	A, C, D50, D65, F2, F6, F7, F8, F10, F11, F12, J, D50, ID65, User illuminant (simultaneous evaluation with two illuminants possible)
Displayed data	Spectral values/graph, colorimetric values/graph, color-difference values/graph, pass/fail judgement, pseudocolor
Colorimetric data	L*a*b*, L*C*h, Hunter Lab, Yxy, XYZ, and color differences in these spaces; Munsell
Indexes	MI, WI (ASTM E313), YI (ASTM E313, ASTM D1925), ISO Brightness (ISO2470), WI/Tint (CIE)
Color-difference formula	ΔE^*ab (CIE 1976), ΔE^*94 (CIE 1994), ΔE_{00} (CIE DE2000), CMC (l:c), ΔE (Hunter)
Standard compliance	CIE No.15, ISO 7724/1, ASTM E179, DIN 5033 part7, JIS Z8722
Measurement geometry	60°
Light source	LED
Detector	Silicon photo diode
Measurement range	0-200 GU; Output/display resolution : 0.01 GU
Measurement area	MAV: Ø10 mm, SAV: Ø3 mm
Repeatability	0-10 GU : 0.1 GU 10-100 GU : 0.2 GU >100 GU : 0.2 % of displayed value (Under Konica Minolta standard measurement conditions)
Inter-instrument agreement	0-10 GU : ±0.2 GU 10-100 GU : ±0.5 GU (MAV. Compared to values measured with a master body under Konica Minolta standard measurement conditions)
Standard compliance	JIS Z8741, JIS K5600, ISO 2813, ISO 7668, ASTM D523-08, ASTM D2457-13, DIN 67530
Measurement time	Approx. 1 seconds (to data display/output)
Minimum measurement interval	Approx. 2 seconds
Battery performance	Approx. 3,000 measurements/charge (Stand-alone measurement at 10-second intervals at 23°C) Approx. 1,000 measurements/charge (When using Bluetooth® communication)
Displayed languages	Japanese, English, German, French, Italian, Spanish, Chinese (Simplified), Portuguese, Russian, Turkish, Polish
Display	2.7-inch TFT color LCD
Interfaces	USB2.0, Bluetooth (Option)
Data memory	Target data: 2,500 measurements; Sample data: 7,500 measurements
Power	Rechargeable lithium-ion battery, USB bus power
Charging time	Approx. 6 hours when no charge remains
Operation temperature/humidity range	5-40 °C, relative humidity is 80% or less (at 35°C) with no condensation
Storage temperature/humidity range	0-45 °C, relative humidity is 80% or less (at 35°C) with no condensation
Size (L×W×H)	224 x 81 x 81 mm
Weight	Approx. 600 g (Including battery)

System Diagram

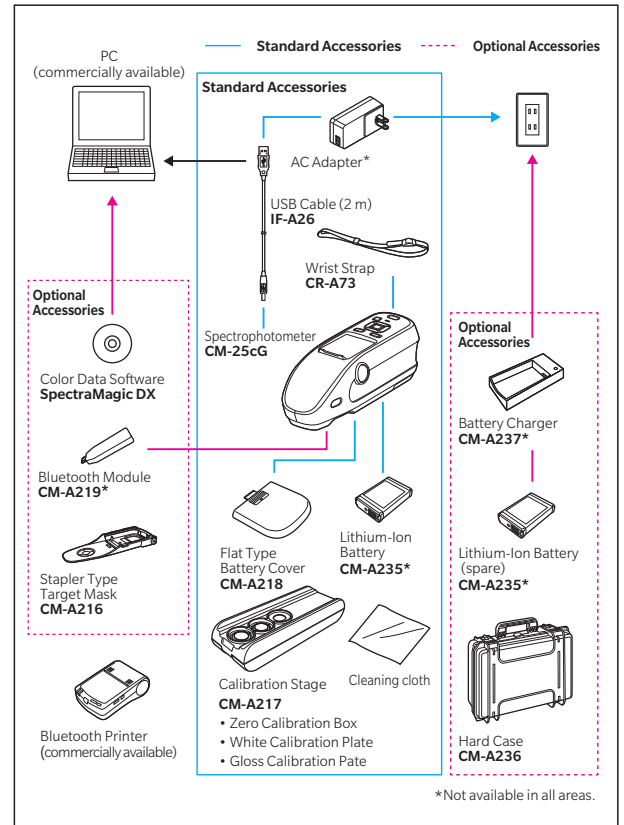

Dimensions (Units : mm)

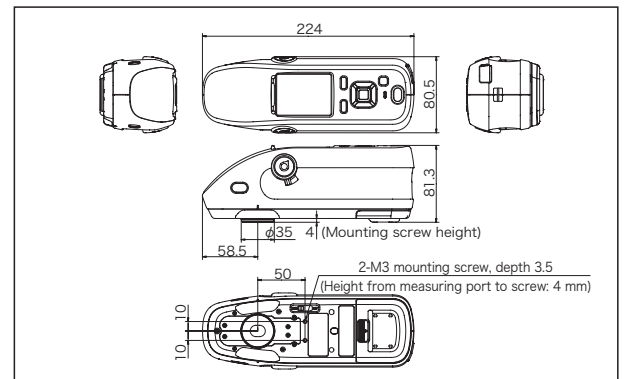

- KONICA MINOLTA, the Konica Minolta logo and symbol mark, "Giving Shape to Ideas" and SpectraMagic are registered trademarks or trademarks of Konica Minolta, Inc.
- Bluetooth® is a registered trademark of Bluetooth SIG, Inc. and is used under license agreement.
- Displays shown are for illustration purpose only.
- The specifications and appearance shown herein are subject to change without notice.



SAFETY PRECAUTIONS

For correct use and for your safety, be sure to read the instruction manual before using the instrument.

- Always connect the instrument to the specified power supply voltage. Improper connection may cause a fire or electric shock.
- Be sure to use the specified batteries. Using improper batteries may cause a fire or electric shock.



Certificate No.: L/RQ 0960094/A
Registration Date: March 3, 1995



Certificate No.: JQA-E-80027
Registration Date: March 12, 1997

KONICA MINOLTA, INC.
Konica Minolta Sensing Americas, Inc.
Konica Minolta Sensing Europe B.V.

Osaka, Japan
New Jersey, U.S.A.
European Headquarter /BENELUX
German Office
French Office
UK Office
Italian Office
Swiss Office
Nordic Office
Polish Office
SE Sales Division
Beijing Office
Guangzhou Office
Chongqing Office
Qingdao Office
Wuhan Office

Phone : 888-473-2656 (in USA), 201-236-4300 (outside USA)
Nieuwegein, Netherlands **Phone** : +31 (0)30 248-1193
München, Germany **Phone** : +49 (0)89 4357 156 0
Roissy CDG, France **Phone** : +33 (0)1 80 11 10 70
Warrington, United Kingdom **Phone** : +44 (0)1925 467300
Cinisello Balsamo, Italy **Phone** : +39 02849488.00
Dietikon, Switzerland **Phone** : +41 (0)43 322-9800
Västra Frölunda, Sweden **Phone** : +46 (0)31 7099464
Wroclaw, Poland **Phone** : +48 (0)71 73452-11
Shanghai, China **Phone** : +86- (0)21-5489 0202
Beijing, China **Phone** : +86- (0)10-8522 1551
Guangdong, China **Phone** : +86- (0)20-3826 4220
Chongqing, China **Phone** : +86- (0)23-6773 4988
Shandong, China **Phone** : +86- (0)532-8079 1871
Hubei, China **Phone** : +86- (0)27-8544 9942
Singapore **Phone** : +65 6563-5533
Goyang-si, Korea **Phone** : +82 (0)2-523-9726

Fax : 201-785-2482
Fax : +31 (0)30 248-1280
Fax : +49 (0)89 4357 156 99
Fax : +33 (0)1 80 11 10 82
Fax : +44 (0)1925 711143
Fax : +39 02849488.30
Fax : +41 (0)43 322-9809
Fax : +48 (0)71 734 52 10
Fax : +86- (0)21-5489 0005
Fax : +86- (0)10-8522 1241
Fax : +86- (0)20-3826 4223
Fax : +86- (0)23-6773 4799
Fax : +86- (0)532-8079 1873
Fax : +86- (0)27-8544 9991
Fax : +65 6560-9721
Fax : +82 (0)31-995-6511

Konica Minolta (CHINA) Investment Ltd.

Konica Minolta Sensing Singapore Pte Ltd.
Konica Minolta Sensing Korea Co., Ltd.

Addresses and telephone/fax numbers are subject to change without notice. For the latest contact information, please refer to the KONICA MINOLTA Worldwide Offices web page :

<http://konicaminolta.com/instruments/network>