

Main specifications

Model	CM-700d	CM-600d
Illumination/viewing system	di: 8°, de: 8° (diffused illumination, 8-degree viewing angle), SCI (specular component included)/SCE (specular component excluded) selectable with automatic switching (Conforms to CIE No. 15, ISO 7724/1, DIN5033 Teil7, ASTM E 1164, and JIS Z 8722)	
Size of integrating sphere	ø40 mm	
Detector	Silicon photodiode array (dual 36-element)	
Spectral separation device	Diffraction grating	
Wavelength range	400 nm to 700 nm	
Wavelength pitch	10 nm	
Half bandwidth	Approx. 10 nm	
Reflectance range	0 to 175%, Display resolution: 0.01%	
Light source	Pulsed xenon lamp (with UV cut filter)	
Measurement time	Approx. 1 second	
Minimum measurement interval	Approx. 2 seconds (in SCI or SCE mode)	
Battery performance	With alkaline dry batteries: Approx. 2,000 measurements With nickel-metal-hydride rechargeable batteries (2300 mAh): Approx. 2,000 measurements with full charge * Stand-alone continuous measurement fixed to either SCI or SCE mode at 10-second intervals at 23°C	
Measurement/illumination area	MAV: ø8 mm/ ø11 mm SAV: ø3 mm/ ø6 mm * Changeable by replacing target mask and selecting lens position	MAV: ø8 mm/ ø11 mm only
Repeatability	Spectral reflectance: Standard deviation within 0.1%, Chromaticity value: Standard deviation within ΔE*ab 0.04 * When a white calibration plate is measured 30 times at 10-second intervals after white calibration	
Inter-instrument agreement	Within ΔE*ab 0.2 (MAV/SCI) * Based on 12 BCRA Series II color tiles compared to values measured with a master body at 23°C	
No. of averaging measurements	1 to 10 (Auto averaging), 1 to 30 (Manual averaging)	
Display	2.36-inch TFT color LCD	
Interfaces	USB1.1; Bluetooth® standard version 1.2*	
Observer	2° observer or 10° observer	
Illuminant	A, C, D50, D65, F2, F6, F7, F8, F10, F11, F12 (Simultaneous evaluation with two light sources possible)	
Displayed data	Spectral values/graph, colorimetric values, color difference values/graph, PASS/FAIL result, pseudocolor, color assessment	
Color spaces	L*a*b*, L*C*h, Hunter Lab, Yxy, XYZ, Munsell, and color difference in these spaces (except for Munsell)	
Colorimetric data	MI, WI (ASTM E313-73/E313-96), YI (ASTM E313-73/ASTM D1925), ISO Brightness, 8° gloss value	
Color difference formulas	ΔE*ab (CIE1976), ΔE*94 (CIE1994), ΔE00 (CIE 2000), CMC (l: c)	
Storable data sets	Measurement data: 4,000 sets/Target color difference data: 1,000 sets	
Pass/fail judgment	Tolerances can be set to colorimetric values (excluding Munsell), color difference values, color values (excluding 8° gloss value) respectively	
Power	Special AC adapter; 4 AA-size alkaline dry batteries or nickel-metal-hydride rechargeable batteries	
Size	73 (W) x 211.5 (H) x 107 (D) mm	
Weight	Approx. 550 g (without white calibration cap and batteries)	
Operating temperature/humidity range	5 to 40°C, relative humidity 80% or less (at 35°C) with no condensation	
Storage temperature/humidity range	0 to 45°C, relative humidity 80% or less (at 35°C) with no condensation	

* Applicable Bluetooth® profile: Serial Port Profile, Output: Bluetooth® Power Class 1 The communication distance may vary depending on the obstacles and radio wave conditions between the devices. Successful wireless communication is not guaranteed with all Bluetooth®-ready equipment.

• Bluetooth® is a registered trademark of Bluetooth SIG, Inc. and is used under license agreement.

Outer dimensions (Units: mm)

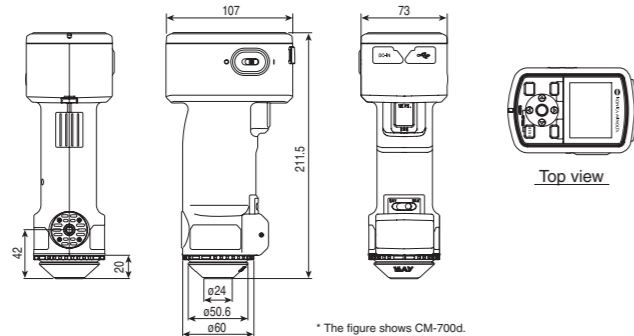

SAFETY PRECAUTIONS

For correct use and for your safety, be sure to read the instruction manual before using the instrument.

- Always connect the instrument to the specified power supply voltage. Improper connection may cause a fire or electric shock.
- Be sure to use the specified batteries. Using improper batteries may cause a fire or electric shock.

The specifications and drawings given here are subject to change without prior notice.
- If you have any questions about specifications, please contact your Konica Minolta representative.



Certificate No.: YKA 0937154
Registration Date: March 3, 1995



Certificate No.: JQA-E-80027
Registration Date: March 12, 1997

KONICA MINOLTA SENSING, INC.
Konica Minolta Sensing Americas, Inc.
Konica Minolta Sensing Europe B.V.

Osaka, Japan
New Jersey, U.S.A.
European Headquarter /BENELUX
German Office
French Office
UK Office
Italian Office
Belgian Office
Swiss Office
Nordic Office
Austrian Office
Polish Office

Konica Minolta (CHINA) Investment Ltd.

SE Sales Division
SE Beijing Office
SE Guangzhou Office

Konica Minolta Sensing Singapore Pte Ltd.

KONICA MINOLTA SENSING, INC. Seoul Office

Osaka, Japan
New Jersey, U.S.A.
European Headquarter /BENELUX
German Office
French Office
UK Office
Italian Office
Belgian Office
Swiss Office
Nordic Office
Austrian Office
Polish Office
SE Sales Division
SE Beijing Office
SE Guangzhou Office
Konica Minolta Sensing Singapore Pte Ltd.
KONICA MINOLTA SENSING, INC. Seoul Office

Phone : 888-473-2656(in USA), 201-236-4300(outside USA) Fax : 201-785-2480
Phone : +31(0)30 248-1193 Fax : +31(0)30 248-1280
Phone : +49(0)89 630267-9700 Fax : +49(0)89 630267-9799
Phone : +33(0)1 493-82519 Fax : +33(0)1 493-84771
Phone : +44(0)1908 540-622 Fax : +44(0)1908 540-629
Phone : +39 02 39011.425 Fax : +39 02 39011.223
Phone : +32 (0)2 7170 933 Fax : +32 (0)2 7170 977
Phone : +41(0)43 322-9800 Fax : +41(0)43 322-9809
Phone : +46(0)31 7099464 Fax : +46(0)31 474945
Phone : +43(0)1 87882-430 Fax : +43(0)1 87882-431
Phone : +48(0)22 56033-00 Fax : +48(0)22 56033-01
Phone : +86-021-5489 0202 Fax : +86-021-5489 0005
Phone : +86-010-8522 1551 Fax : +86-010-8522 1241
Phone : +86-020-3826 4220 Fax : +86-020-3826 4223
Phone : +65 6563-5533 Fax : +65 6560-9721
Phone : +82(0)2-523-9726 Fax : +82(0)2-523-9729

Addresses and telephone/fax numbers are subject to change without notice. For the latest contact information, please refer to the KONICA MINOLTA SENSING Worldwide Offices web page:

©2007 KONICA MINOLTA SENSING, INC.

<http://konicaminolta.com/instruments/about/network>

9242-4894-10 AHMAPK①



Spectrophotometer NEW CM-700d/600d

Compact, lightweight, portable spectrophotometer with wireless communication and color LCD screen

Field-oriented spectrophotometer for reliable color measurement

Unprecedented ease of handling and easy operation with color LCD screen



The essentials of imaging

CM-700d/600d: Compact, lightweight spectrophotometers with wireless communication and color LCD screen, offering excellent portability and operability!

We are surrounded by abundant colors. In the automotive, home appliance, portable phone, textile and clothing industries the variation in colors are increasing in order to differentiate products. In the food industry, the importance of color management continues to rise. Under such circumstances, the applications of color-measuring instruments have been rapidly spreading from R&D or QC departments to production sites, as well as from product manufacturers to parts/material suppliers.

The CM-700d/600d is a spectrophotometer that has achieved a much more compact and lightweight body while retaining the sophisticated functions of Konica Minolta's conventional models by utilizing our original optical design and signal processing technologies. It allows easy and accurate color measurement in various sites and occasions.

The easy-to-read color LCD screen allows intuitive recognition of measurement results. Experience the ease for yourself!

Perfect design to fit in your hand

- Ergonomic, compact and lightweight
- Vertical format for easy positioning
- Excellent portability for production sites



Measure anywhere!

The tapered measuring head allows for easy checking of measurement positions. The upright design ensures easy measurement, even on concave surfaces. The measuring aperture is selectable between $\phi 8$ mm and $\phi 3$ mm according to the sample size (CM-700d only).



Bluetooth® compatible!

Data can be sent to a PC or a mobile printer via Bluetooth® wireless communication. (USB communication with a PC is also possible.)



Automatic switching for SCI and SCE measurement

Large memory capacity

No. of storable data sets
Target data: 1,000 sets
Measurement data: 4,000 sets



Standard accessories



Optional accessories



Easy to operate!

Dedicated buttons for frequently used operations make it easy to call up menus or target colors. The menu-driven display allows anyone to operate the instrument intuitively.

Easy-to-read color LCD screen!

Abundant information is displayed in color for easy understanding. Measured colors can also be reproduced as color patches on the color LCD, which is useful to check the level of color difference or to search for colors.



Spectral graph

Pseudocolor

Color difference graph



Color Data Software SpectraMagic™ NX CM-S100w (Optional accessory)

(Version 1.8 or later)

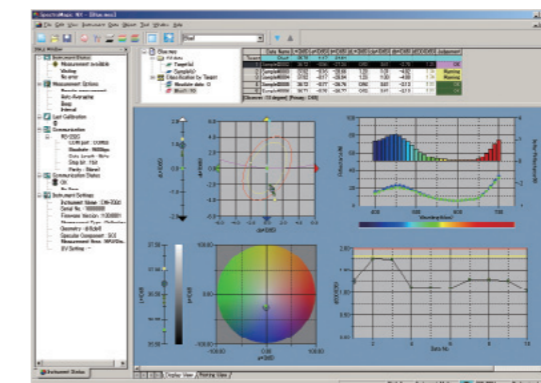

Screen creation according to the application

You can create screens suitable for your application by laying out and editing various objects including data lists, spectral graphs, color difference graphs and Pass/Fail displays. You can also create print screens to print inspection reports after measurements.

OS: Windows® 2000 Professional SP4, Windows® XP Professional SP2, x64 Edition, Windows® Vista Business 32 bit (x86), 64 bit (x64) **CPU:** Pentium® III 600 MHz equivalent or faster (recommended) **Memory:** 128 MB or more (256 MB or more recommended) **Hard disk:** 450 MB or more of free space for installation **Display:** Resolution: 1024 x 768 dots or more/ 256-bit colors or more **Other:** CD-ROM drive (required at software installation), USB port (required to connect the protect key), USB port or serial port (required to connect the instrument), Internet Explorer Version. 5.01 or higher installed in the computer.

• Windows® is a trademark or registered trademark of Microsoft Corporation in the USA and other countries. • Pentium® is a trademark of Intel Corporation in the USA and other countries. • The specifications given here are subject to change without prior notice.

<System Configuration>

