



KONICA MINOLTA

MULTI GLOSS 268 Plus (20°, 60°, 85°) UNI GLOSS 60Plus (60°)

NEW

More comprehensive communication functions for more versatility.

- Maintains data compatibility with previous models while offering high-speed communication via USB and Bluetooth®.

- Approx. 10,000 are possible measurements with one AA (R6) size alkaline battery.

Large easy to read liquid crystal display. Easy operation with mode scroll wheel.

By operating the mode scroll wheel in accordance with easy-to-understand menu items, you can set a wide array of functions easily.



You can select Mode, Geometry selection, Difference, and Calibration from the Main Menu screen.

Wide array of display modes (in nine languages)

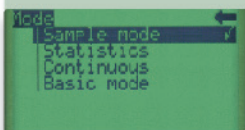

You can measure by selecting Basic mode, Continuous, or Statistics from the Mode screen.

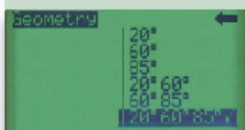

You can select the measurement angle from the Geometry selection screen and display two angles or three angles at the same time.

(MULTI GLOSS 268Plus)

Wide measurement range that can measure from matte plastic to metal surface with a high gloss finish : 0.0~2,000 GU

(in the case of 20°)

Gloss difference measurement of standard/sample and PASS/FAIL evaluation.

You can perform a pass/fail evaluation by setting the limit value. You can enter the sample name and the standard value name in the measurement result.

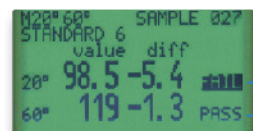

Geometric selection selected two angles. (MULTI GLOSS 268)

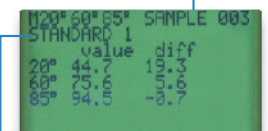

Geometric selection selected three angles. (MULTI GLOSS 268)

Autodiagnosis function for calibration

Reduces needed frequency of calibration and improves long-term stability. In addition, if the calibration is required, the message will be displayed.

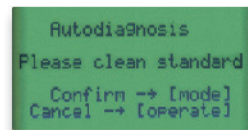

Calibrating standard



Protective holder

The essentials of imaging

With dedicated Data transfer software (gloss-link), data management such as data transfer to Excel®* is easy.



OS Windows®2000/XP/Vista

* Microsoft Excel® 2000 or higher.
Windows® and Excel® is a trademark or registered trademark of Microsoft Corporation of America or its subsidiaries.

Dimensions

Units : mm

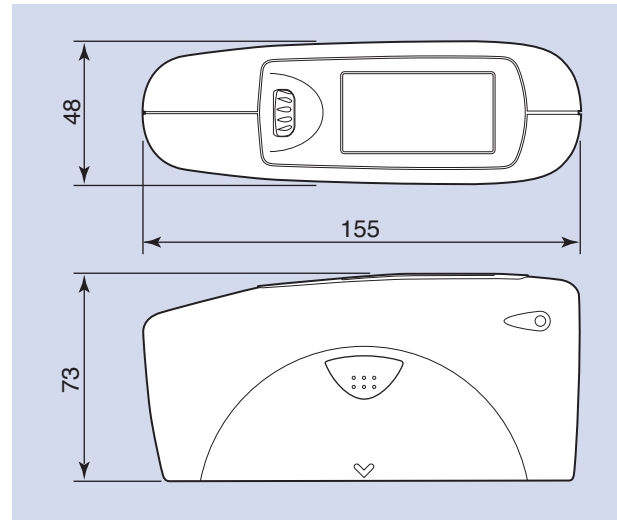

Specifications

| Model | MULTI GLOSS 268Plus | UNI GLOSS 60Plus |
|---------------------------------------|--|--------------------|
| Measurement geometry | 20°, 60°, 85° | 60° |
| Size of measurement spot | 20° : 10 X 10 mm 60° : 9 X 15 mm 85° : 5 X 38 mm | 60° : 9 X 15 mm |
| Standard compliance | ISO 2813, ISO 7668, ASTM D 523, ASTM D 2457, DIN 67 530, JIS Z 8741, BS 3900, BS 6161(Part 12) | |
| Measurement range | 20° : 0.0~2,000 GU 60° : 0.0~1,000 GU 85° : 0.0~160 GU | 60° : 0.0~1,000 GU |
| Resolution | 0.0~99.9 GU : 0.1 GU 100~2,000 GU : 1 GU | |
| Repeatability | 0.0~99.9 GU : 0.2 GU 100~2,000 GU : 0.2% of reading | |
| Inter instrument agreement | 0.0~99.9 GU : 0.5 GU 100~2,000 GU : 0.5% of reading | |
| Memory | 999 measurements with date and time | |
| Difference measurement | Memory for 50 standard | |
| Battery performance | Approx. 10,000 measurements (when using 1.5 V AA(R6) size alkaline battery) | |
| Measurement time | 0.5 seconds | |
| Auto power off | 10~99 seconds selectable | |
| Languages | English, Spanish, German, French, Italian, Japanese, Portuguese, Russian, Polish | |
| Measurement mode | Normal mode (Sample mode, Statistics, Continuous, Basic mode), Difference mode | |
| Interface | USB2.0; Bluetooth® standard version 2.0* | |
| Operating temperature /humidity range | 15 to 40°C relative humidity 85% or less (at 35°C) with no condensation | |
| Storage temperature /humidity range | -10 to 60°C relative humidity 85% or less (at 35°C) with no condensation | |
| Power supply | 1.5 V AA(R6) size alkaline battery, via USB port | |
| Dimensions | 155(W) X 73(H) X 48(D) mm | |
| Weight | 400 g | |

Note : The specifications described in this document are subject to change without notice.

Accessories

| Model | MULTI GLOSS 268Plus | UNI GLOSS 60Plus |
|----------------------|---|--|
| Standard accessories | Calibration holder TRI (High gloss tile) USB-cable Carrying case Data transfer software (gloss-link) 1.5 V AA(R6) size alkaline battery | Calibration holder 60° (High gloss tile) |
| Optional accessories | Checking standard TRI (3 semi gloss tiles 20, 60, 85°) Checking standard mirror (3 tiles 20, 60, 85°) | Checking standard 60° (High and semi gloss tile) |

* Applicable Bluetooth® profile: Serial Port Profile, Output: Bluetooth® Power Class 1 The communication distance may vary depending on the obstacles and radio wave conditions between the devices. Successful wireless communication is not guaranteed with all Bluetooth®-ready equipment.

* Bluetooth® is a registered trademark of Bluetooth SIG, Inc.

MULTI GLOSS 268 / UNI GLOSS 60 conforms with international specifications ASTM D 523, DIN 67 530, ISO 2813.

ASTM DIN ISO



Certificate No : YKA 0937154
Registration Date : March 3, 1995

Certificate No : JQA-E-80027
Registration Date : March 12, 1997

SAFETY PRECAUTIONS



For correct use and for your safety, be sure to read the instruction manual before using the instrument.

- Always connect the instrument to the specified power supply voltage. Improper connection may cause a fire or electric shock.
- Be sure to use the specified batteries. Using improper batteries may cause a fire or electric shock.

KONICA MINOLTA SENSING, INC.
Konica Minolta Sensing Americas, Inc.
Konica Minolta Sensing Europe B.V.

Osaka, Japan
New Jersey, U.S.A.
European Headquarter /BENELUX
German Office
French Office
UK Office
Italian Office
Belgian Office
Swiss Office
Nordic Office
Austrian Office
Polish Office

Phone : 888-473-2656(in USA), 201-236-4300(outside USA)
Nieuwegein, Netherlands
München, Germany
Roissy CDG, France
Milton Keynes, United Kingdom
Milan, Italy
Zaventem, Belgium
Dietikon, Switzerland
Västra Frölunda, Sweden
Wien, Austria
Wrocław, Poland
Shanghai, China
Beijing, China
Guangzhou, China
Chongqing, China
Qingdao, China
Singapore
Seoul, Korea

Fax : 201-785-2482
Fax : +31(0)30 248-1280
Fax : +49(0)89 4357 156 99
Fax : +33(0)1 493-84771
Fax : +44(0)1908 540-629
Fax : +39 02 39011.223
Fax : +32 (0)2 7170 977
Fax : +41(0)43 322-9809
Fax : +46(0)31 474945
Fax : +43(0)1 87882-431
Fax : +48(0)71 734 52 10
Fax : +86-021-5489 0005
Fax : +86-010-8522 1241
Fax : +86-020-3826 4223
Fax : +86-023-6773 4799
Fax : +86-0532-8079 1873
Fax : +65 6560-9721
Fax : +82(0)2-523-9729

Konica Minolta (CHINA) Investment Ltd.
SE Sales Division
Beijing Branch
Guangzhou Branch
Chongqing Office
Qingdao Office

Konica Minolta Sensing Singapore Pte Ltd.
KONICA MINOLTA SENSING, INC. Seoul Office

Addresses and telephone/fax numbers are subject to change without notice. For the latest contact information, please refer to the KONICA MINOLTA SENSING Worldwide Offices web page :

<http://konicaminolta.com/instruments/about/network>