



KONICA MINOLTA

SPECTROPHOTOMETER CM-2500d

High performance, low cost
portable spectrophotometer.

31



The Standard in Measuring Color & Light

Giving Shape to Ideas

Designed for versatility in various applications, the CM-2500d is a portable integrating sphere spectrophotometer incorporating Numerical Gloss Control.

Simultaneous measurement of SCI (specular component included) and SCE (specular component excluded). Advanced Numerical Gloss Control.

Simultaneous measurement of SCI and SCE displays the data on the LCD in only 1.5 seconds. Unlike conventional spectrophotometers, there is no need to mechanically switch between SCI and SCE mode. This improves working efficiency and provides stable measured data since the measurement area does not shift when the mode is switched. And also Relativity Gloss Value can be displayed by using Numerical Gloss Control.



For plastics, paints, resins and consumer products

High reliability and long life. Maintenance-free design.

The number of moving parts in the instrument is minimized through the introduction of numerical control technology. The CM-2500d can be used with confidence, since it has been developed, manufactured and calibrated to meet ISO 9001 requirements.

Allows measurement in any position. Compact, lightweight, with an easy-to-operate navigation wheel and large LCD display.

The battery-powered small, light body allows the instrument to be placed in any position at the sample surface. The CM-2500d's large LCD display and its reverse display function provide easy reading, irrespective of which hand it is held in. Using your finger, the navigation wheel allows simple, user friendly operation.

(Turn) (Push)



For paints, plastics, automobiles, ceramics, architectural interiors, textile, paper, food etc.

Promotes accurate, consistent color communication. Conforms to widely-accepted industry standards and allows measurements in all popular color spaces.

The optics use an integrating sphere to provide diffuse illumination/8-degree viewing system.

The CM-2500d conforms to all widely accepted standards including ISO, JIS, DIN, CIE and ASTM, and generates measurements in color notations such as L*a*b*, Yxy, Munsell and CIE2000.

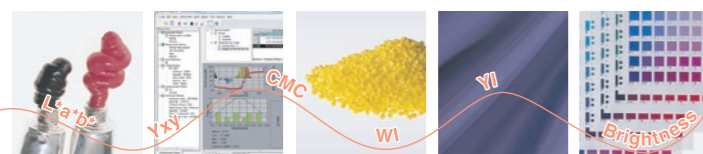

In various applications

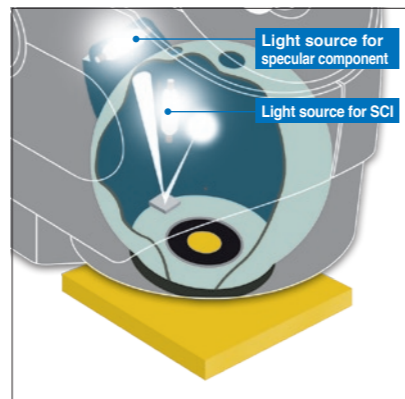

The LCD specifications are subject to change without prior notice.

• SCI is a method in which measurements are taken with the specular reflection included. For this reason, it minimizes influences of the surface condition of a sample, and is especially suitable for color quality control and Computer Color Matching.

• SCE is a method in which measurements are taken excluding the specular reflection. This type of measurement provides results similar to those observed visually.

Expanded LCD display (64 x 240 dots)
Displays large quantities of information (simultaneous display of SCI and SCE data etc.)

High-accuracy sensor
Measures at 10nm intervals for the full wavelength range. Excellent repeatability

Illuminated viewfinder

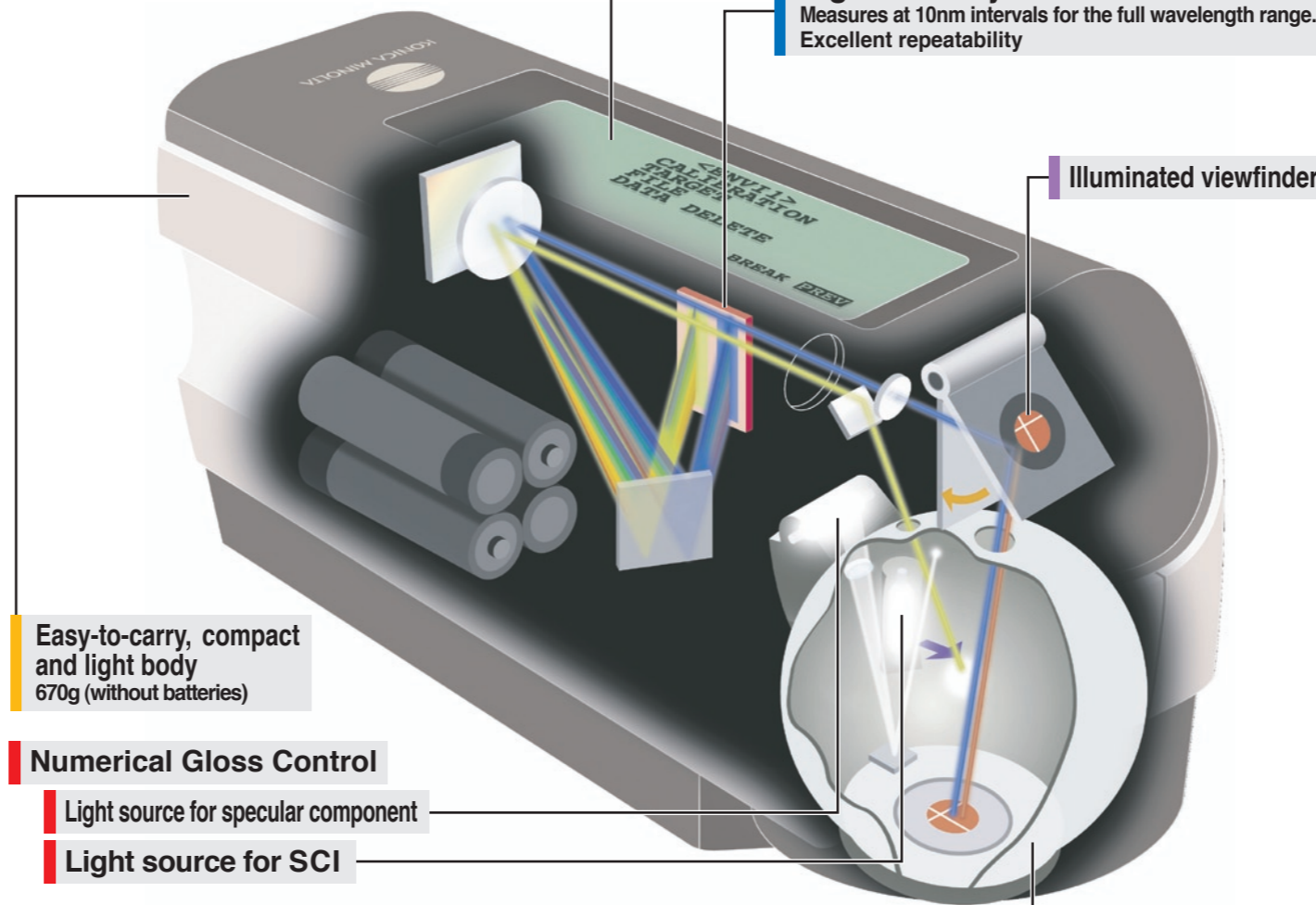

Easy-to-carry, compact and light body
670g (without batteries)

Numerical Gloss Control

Light source for specular component

Light source for SCI

Measures the target with high accuracy. Easy-to-carry stylish body with an illuminated viewfinder.

The user can choose the most suitable measurement area for the target. The easy-to-carry body with the illuminated viewfinder enables the user to position the instrument on the target quickly and accurately.



For pharmaceuticals, cosmetics, printing, building materials, textiles, food etc.

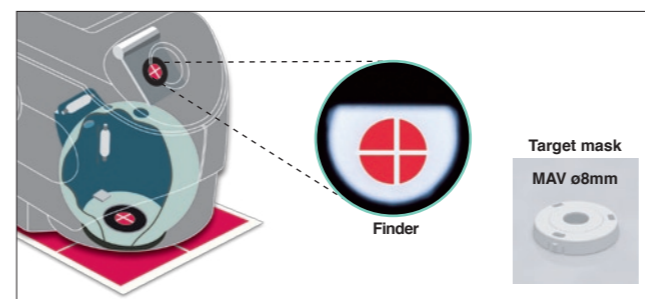

Powerful partnership between CM-2500d and SpectraMagic™ NX

Color Data Software

SpectraMagic™ NX (Optional)

Supports Windows® Vista/7/8.1/10

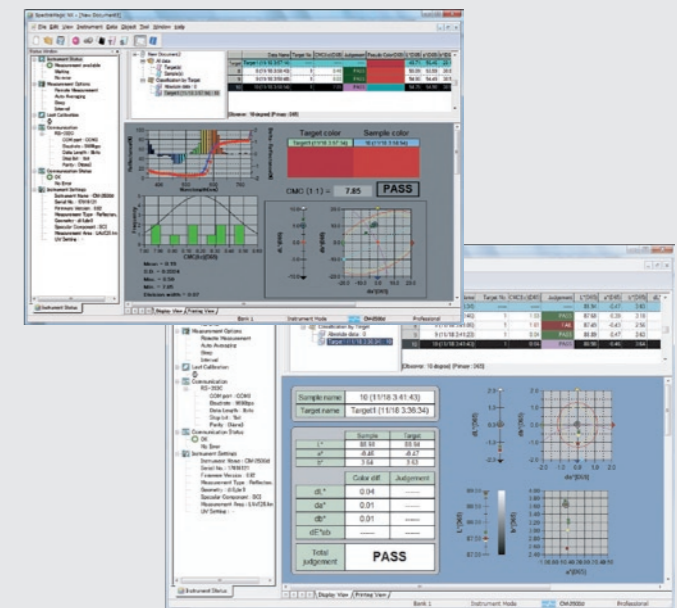
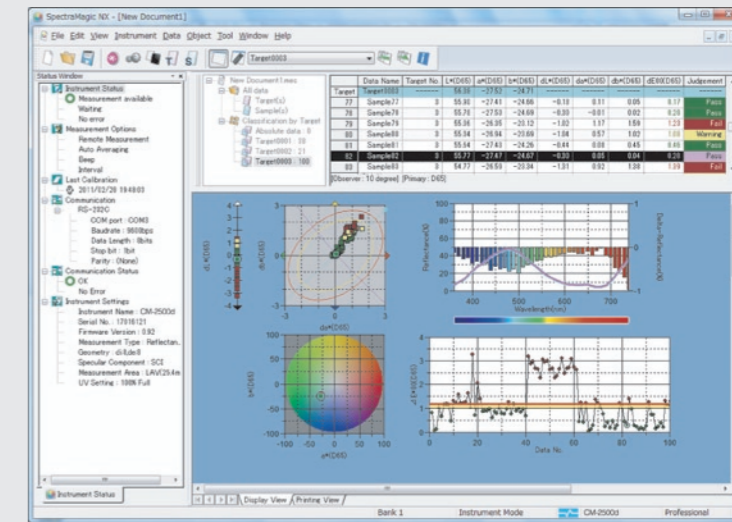

SpectraMagic™ NX enables you to perform comprehensive color inspection and analysis of incoming raw materials, in process production, and outbound color critical goods and materials in virtually any industry. With SpectraMagic™ NX you can insert digital images with measured data. Measure samples in any of 8 universally accepted color spaces. Select from 16 illuminants, and up to 40 indices to determine specific color and appearance properties, such as strength, brightness, haze, yellowness, opacity and strength. You can even configure up to 8 customized color equations. Reports range from simple Pass/Fail to trend charts, histograms, color plots, and spectral graphs. SpectraMagic™ NX comes with predefined templates or you can create your own templates. For illustrations and explanations to understanding color and color measurement technology, there is a link to Konica Minolta's well known and respected "Precise Color Communication". Step by step navigation help.

• Windows® is a trademark of Microsoft Corporation in the USA and other countries.

Specifications	
Illumination/viewing system	di:8, de:8 (diffuse illumination, 8-degree viewing), equipped with simultaneous measurement of SCI (specular component included) /SCE (specular component excluded) Conforms to CIE No.15,ISO 7724/1, ASTM E1164, DIN 5033 Teil 7 and JIS Z8722 Condition C standard.
Integrating sphere size	ø52mm
Detector	Silicon photodiode array (dual 40 elements)
Spectral separation device	Diffraction grating
Wavelength range	360nm to 740nm
Wavelength pitch	10nm
Half bandwidth	Approx. 10nm
Reflectance range	0 to 175%, resolution: 0.01%
Light source	2 pulsed xenon lamps
Measurement time	Approx. 1.5 seconds (approx. 2 seconds for fluorescent measurement)
Minimum measurement interval	3 seconds for SCI/SCE (4 seconds for fluorescent measurement)
Battery performance	Alkaline manganese: approx. 1000 measurements
Measurement/illumination area	MAV: ø8mm/ø11mm
Repeatability	Spectral Reflectance: Standard deviation within 0.1% (360 to 380nm within 0.2%) Colorimetric Value: Standard deviation within ΔE^*ab 0.04 (Measurement conditions: White calibration plate measured 30 times at 10-second intervals after white calibration was performed)
Inter-instrument agreement	within ΔE^*ab 0.2 (MAV/SCI) Average for 12BCRA Series II color tiles compared to values measured with master body.
Measurement mode	Single measurement/automatic averaging of multiple measurements (auto mode: 3, 5, 8 times/manual mode)
Interface	Output: RS-232C serial signals via RJ45 connector; USB 2.0 communication possible when using included USB-Serial Converter Cable IF-A24
Observer	2° or 10° Standard Observer
Illuminant	A, C, D50, D65, F2, F6, F7, F8, F10, F11, F12 (simultaneous evaluation is possible using two light sources)
Display data	Spectral value/graph, colorimetric value, color difference value/graph, PASS/FAIL result
Colorimetric data/indexes	L*a*b*, L*C*h, CMC (1:1), CMC (2:1), CIE94, Hunter Lab, Yxy, Munsell, XYZ, MI, WI (ASTM E313-73), YI (ASTM E313-73/ASTM D1925), ISO Brightness (ISO 2470), Density status A/T, WI/Tint (CIE), CIE00
Data memory	1700 pieces of data (as SCI/SCE 1 data) * 700 pieces of data in the " defined in COND." mode. * Total of the sample data for the COND and TASK modes and color difference target data
Pass/Fail judgment	Tolerance for color difference (both box and elliptical tolerances can be set)
Power	AA-size batteries (x4) or AC Adapter
Size (WxHxD)	69 x 96 x 193mm
Weight	Approx. 670g (without batteries)
Operation temperature/humidity range (*1)	5 to 40°C, relative humidity 80% or less (at 35°C) with no condensation
Storage temperature/humidity range	0 to 45°C, relative humidity 80% or less (at 35°C) with no condensation
Standard accessories	White calibration plate, Target mask ø8mm, USB-Serial Converter Cable IF-A24, AC adapter, AA-size batteries (x4)
Optional accessories	Hard Case, Dust Cover Set, Dust Cover, SpectraMagic™NX (software), Zero Calibration Box CM-A32, RS-232C Cable IF-A16

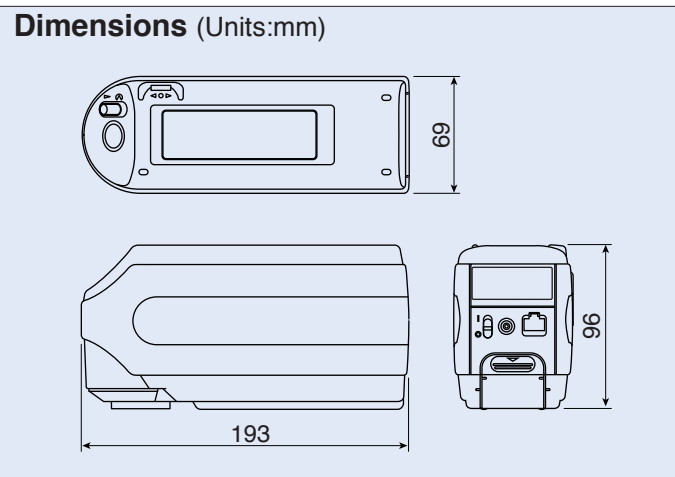
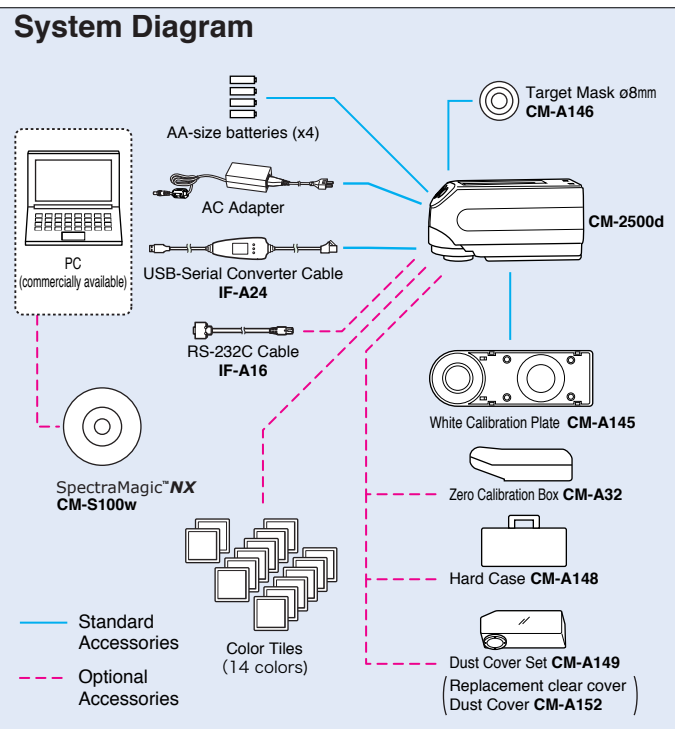

*1 Operation temperature/humidity range of products for North America: 5 to 40°C, relative humidity 80% or less (at 31°C) with no condensation

Color control network by spectrophotometer

High inter-instrument agreement between the portable CM-2500d spectrophotometer and the desktop CM-3000 series make it easy to build a total color control network.

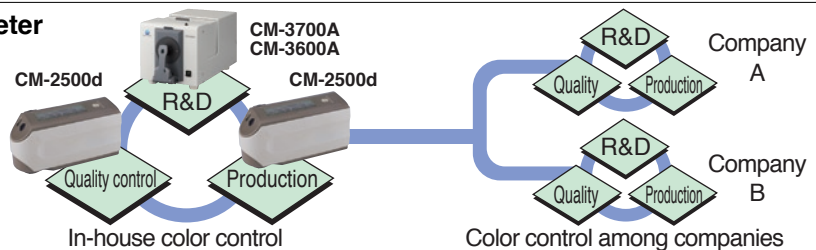

SAFETY PRECAUTIONS



For correct use and for your safety, be sure to read the instruction manual before using the instrument.

- Always connect the instrument to the specified power supply voltage. Improper connection may cause a fire or electric shock. Be sure to use the specified batteries. Using improper batteries
- may cause a fire or electric shock.



Certificate No : L RQ 0960094/A
Registration Date : March 3, 1995



Certificate No : JQA-E-80027
Registration Date : March 12, 1997

* The specifications and appearance shown herein are subject to change without notice.

KONICA MINOLTA, INC.
Konica Minolta Sensing Americas, Inc.
Konica Minolta Sensing Europe B.V.

Osaka, Japan
New Jersey, U.S.A.
European Headquarter /BENELUX
German Office
French Office
UK Office
Italian Office
Swiss Office
Nordic Office
Polish Office
Turkish Office
SE Sales Division
Beijing Office
Guangzhou Office
Chongqing Office
Qingdao Office
Wuhan Office

Phone : 888-473-2656 (in USA), 201-236-4300 (outside USA)
Nieuwegein, Netherlands Phone : +31 (0) 30 248-1193
München, Germany Phone : +49 (0) 89 4357 156 0
Roissy CDG, France Phone : +33 (0) 1 80 11 10 70
Warrington, United Kingdom Phone : +44 (0) 1925 467300
Cinisello Balsamo, Italy Phone : +39 02849488.00
Dietikon, Switzerland Phone : +41 (0) 43 322-9800
Västra Frölunda, Sweden Phone : +46 (0) 31 7099464
Wroclaw, Poland Phone : +48 (0) 71 73452-11
Istanbul, Turkey Phone : +90 (0) 216-528 56 56
Shanghai, China Phone : +86- (0)21-5489 0202
Beijing, China Phone : +86- (0)10-8522 1551
Guangdong, China Phone : +86- (0)20-3826 4220
Chongqing, China Phone : +86- (0)23-6773 4988
Shandong, China Phone : +86- (0)532-8079 1871
Hubei, China Phone : +86- (0)27-8544 9942
Singapore Phone : +65 6563-5533
Goyang-si, Korea Phone : +82 (0) 2-523-9726

Fax : 201-785-2482
Fax : +31 (0) 30 24 81 211
Fax : +49 (0) 89 4357 156 99
Fax : +33 (0) 1 80 11 10 82
Fax : +44 (0) 1925 711143
Fax : +39 02849488.30
Fax : +41 (0) 43 322-9809
Fax : +48 (0) 71 734 52 10
Fax : +90 (0) 212-253 49 69
Fax : +86- (0)21-5489 0005
Fax : +86- (0)10-8522 1241
Fax : +86- (0)20-3826 4223
Fax : +86- (0)23-6773 4799
Fax : +86- (0)532-8079 1873
Fax : +86- (0)27-8544 9991
Fax : +65 6560-9721
Fax : +82 (0)31-995-6511

Konica Minolta (CHINA) Investment Ltd.

Konica Minolta Sensing Singapore Pte Ltd.
Konica Minolta Sensing Korea Co., Ltd.

Addresses and telephone/fax numbers are subject to change without notice. For the latest contact information, please refer to the KONICA MINOLTA Worldwide Offices web page :

©2001-2017 KONICA MINOLTA, INC.

<http://konicaminolta.com/instruments/network>

9242-4879-41 BHPDK Printed in Japan